

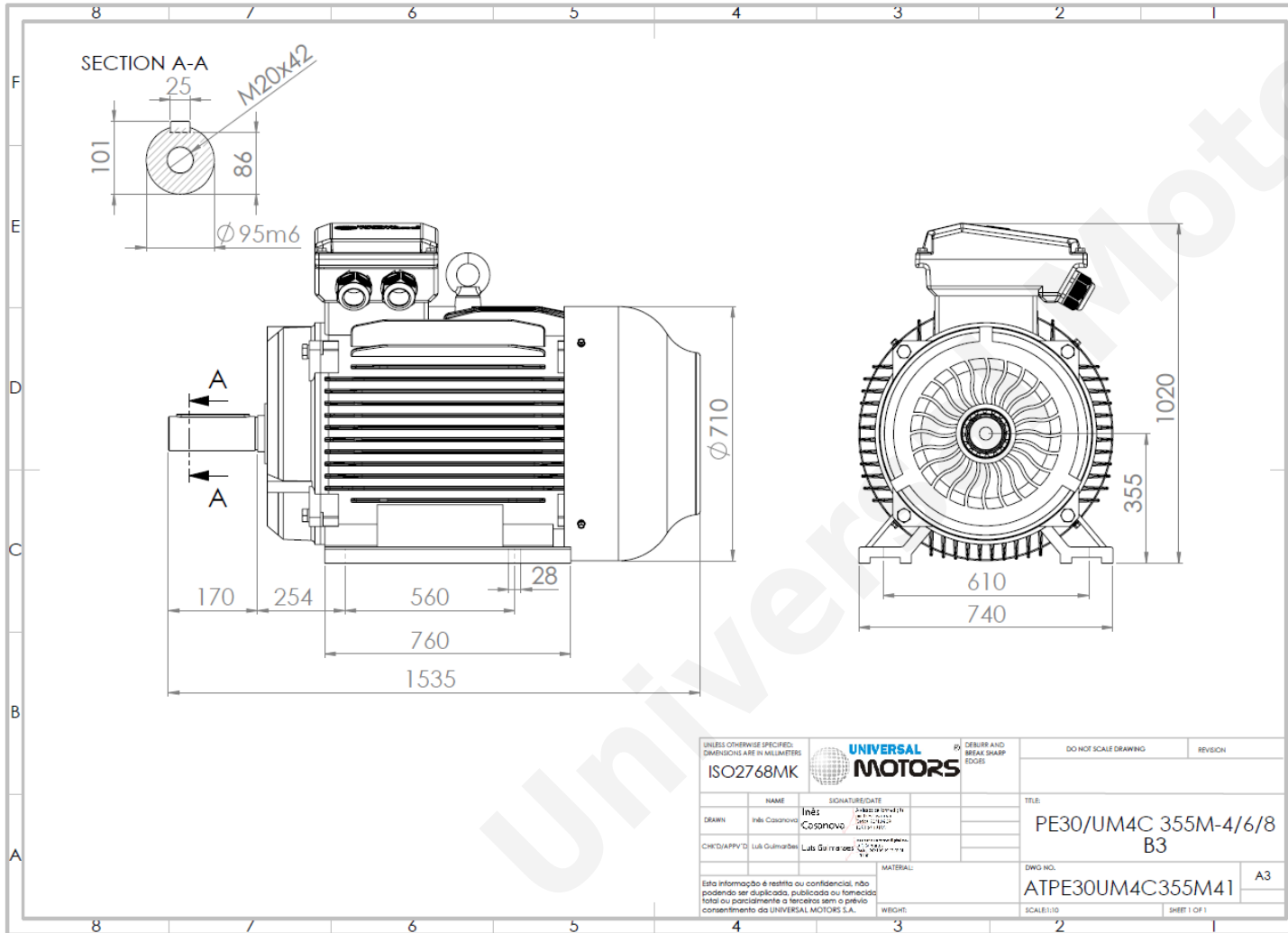

# TECHNICAL DATA

Three Phase Electric Motors - Cast Iron Frame  
 PE30 355 M2 6 IE3  
 200 kW / 270 Cv  
 990 RPM



Motor type:	<b>PE30 355 M2 6 IE3</b>
Output:	<b>200 kW / 270 Cv</b>
Speed (min <sup>-1</sup> ):	<b>990 RPM</b>
Frequency:	<b>50 Hz</b>
Voltage:	<b>400 V</b>
Current:	<b>346 A</b>
Power factor (Cos Ø):	<b>0.87</b>
Poles:	<b>6</b>
Insulation class:	<b>F</b>
Temperature rise Class:	<b>B</b>
Efficiency 50%:	<b>94.5 %</b>
Efficiency 75%:	<b>95.7 %</b>
Efficiency 100%:	<b>95.8 %</b>
Torque:	<b>1929 N.m</b>
Tstarting/Tnominal:	<b>1.8</b>
Istarting/Inominal:	<b>6.8</b>
Tmaximum/Tnominal:	<b>2.0</b>
Noise:	<b>74 Db(A)</b>
Weight:	<b>1630 Kg</b>
Bearing DE:	<b>NU 322</b>
Bearing NDE:	<b>6322 C3</b>

UNLESS OTHERWISE SPECIFIED, DIMENSIONS ARE IN MILLIMETERS		UNIVERSAL MOTORS		DEBURR AND BREAK SHARP EDGES		DO NOT SCALE DRAWING		REVISION	
ISO2768MK									
NAME	INês	SIGNATURE	DATE	TITLE					
DRAWN	Luís Casanova			PE30/UM4C 355M-4/6/8					
CHECK/APPROV'D	Luís Guimarães			B3					
MATERIAL:				DWG. NO.					
				ATPE30UM4C355M41		A3			
Esta informação é restrita ou confidencial, não podendo ser duplicada, publicada ou fornecida total ou parcialmente a terceiros sem o prévio consentimento da UNIVERSAL MOTORS S.A.				WEIGHT:		SCALE:1:10		SHEET 1 OF 1	

Regime - S1

Altitude - 1000m

Environment Temperature - 40°C

## CONTACTS:

UNIVERSAL MOTORS Tel: +351 252 299 080  
 Rua de São Brás,745 Fax: +351 252 299 089  
 4480-782 VILA DO CONDE Mail: [geral@universalmotors.pt](mailto:geral@universalmotors.pt)

\* References applied only in the UK